



US007832956B2

(12) **United States Patent**  
**Ross**

(10) **Patent No.:** **US 7,832,956 B2**  
(45) **Date of Patent:** **Nov. 16, 2010**

- (54) **DENTAL CLEANSER AND STAIN PREVENTION APPARATUS**
- (76) Inventor: **Karen L. Ross**, 2436 Kimberly Ave., Camarillo, CA (US) 93010
- (\* ) Notice: Subject to any disclaimer, the term of this patent is extended or adjusted under 35 U.S.C. 154(b) by 212 days.
- (21) Appl. No.: **11/938,167**
- (22) Filed: **Nov. 9, 2007**
- (65) **Prior Publication Data**  
US 2009/0123217 A1 May 14, 2009
- (51) **Int. Cl.**  
**A46B 17/04** (2006.01)
- (52) **U.S. Cl.** ..... **401/269**; 401/133; 401/134; 401/183
- (58) **Field of Classification Search** ..... 401/183–186, 401/132–135, 268, 270, 269  
See application file for complete search history.

5,184,719 A	2/1993	Gordon	
5,244,096 A	9/1993	Stoner	
5,599,126 A *	2/1997	Hough	401/184
5,775,511 A	7/1998	Stark	
5,954,996 A	9/1999	Discko, Jr.	
6,009,886 A	1/2000	Labranche et al.	
6,062,233 A	5/2000	Williams	
6,311,837 B1	11/2001	Blaustein et al.	
6,401,727 B1	6/2002	Carroll	
6,463,937 B1	10/2002	Cloutier et al.	
6,682,722 B2	1/2004	Majeti et al.	
6,702,113 B2	3/2004	Marino	
6,722,805 B1 *	4/2004	Skinner	401/132
7,270,239 B1	9/2007	Ross	
7,331,731 B2	2/2008	Hohlbein et al.	
7,416,357 B2 *	8/2008	Thiebaut	401/131
7,572,079 B2 *	8/2009	Wong	401/134
2002/0088474 A1	7/2002	Montalvo	
2003/0203338 A1	10/2003	Levine	
2006/0228158 A1	10/2006	Levine et al.	
2007/0209954 A1	9/2007	Aldridge et al.	

\* cited by examiner

*Primary Examiner*—David J Walczak  
(74) *Attorney, Agent, or Firm*—Marvin H. Kleinberg; Marshall A. Lerner; Kleinberg & Lerner, LLP

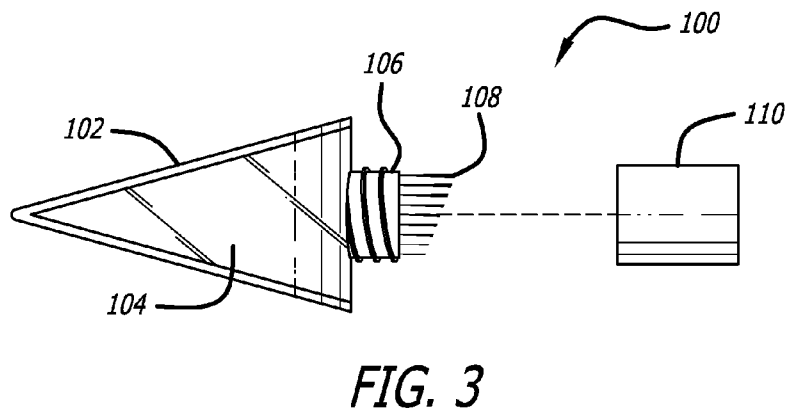
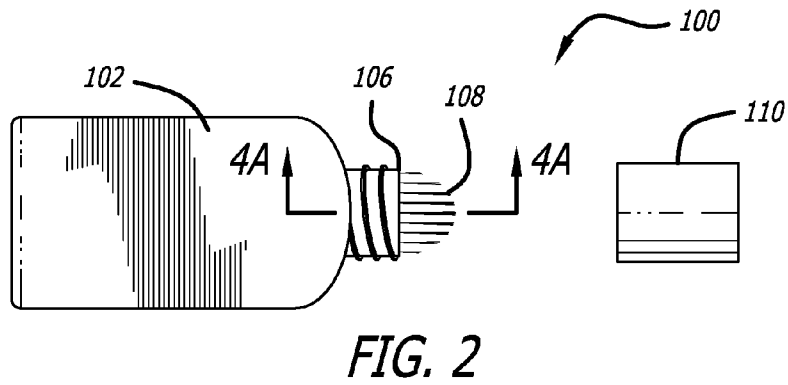
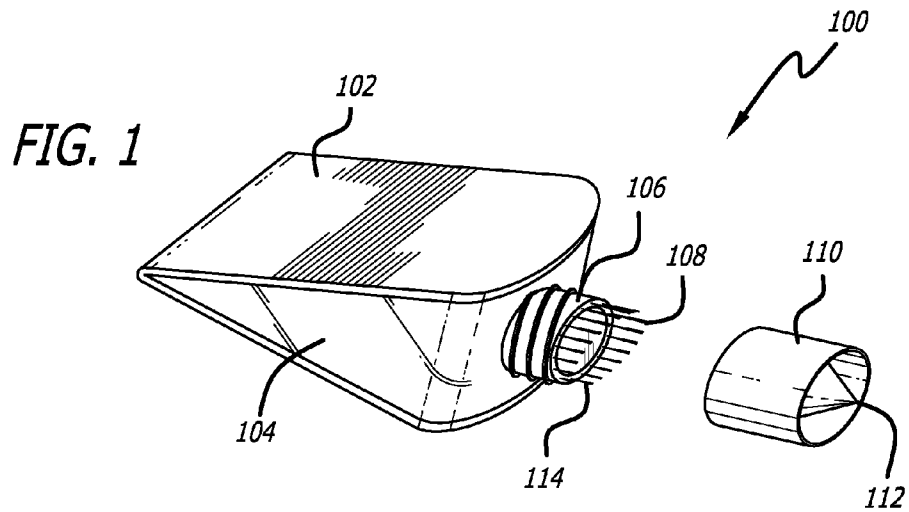
(56) **References Cited**  
U.S. PATENT DOCUMENTS

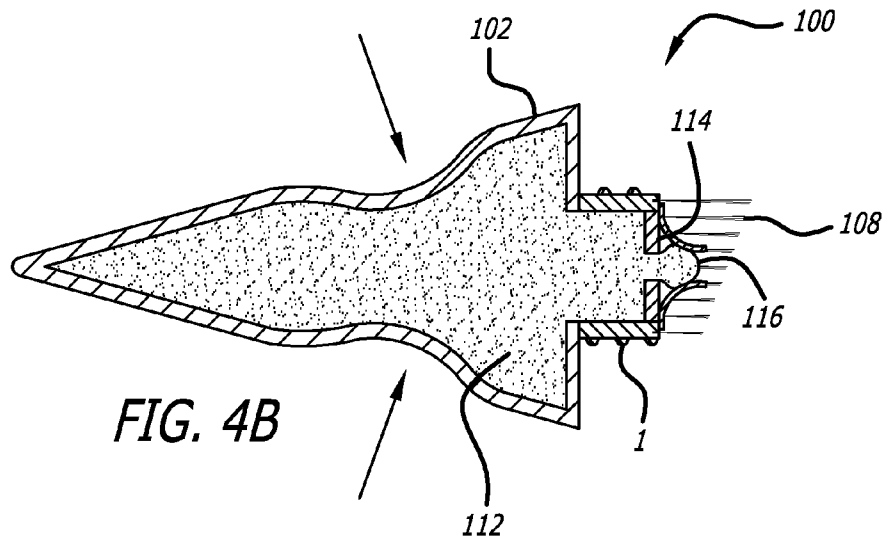
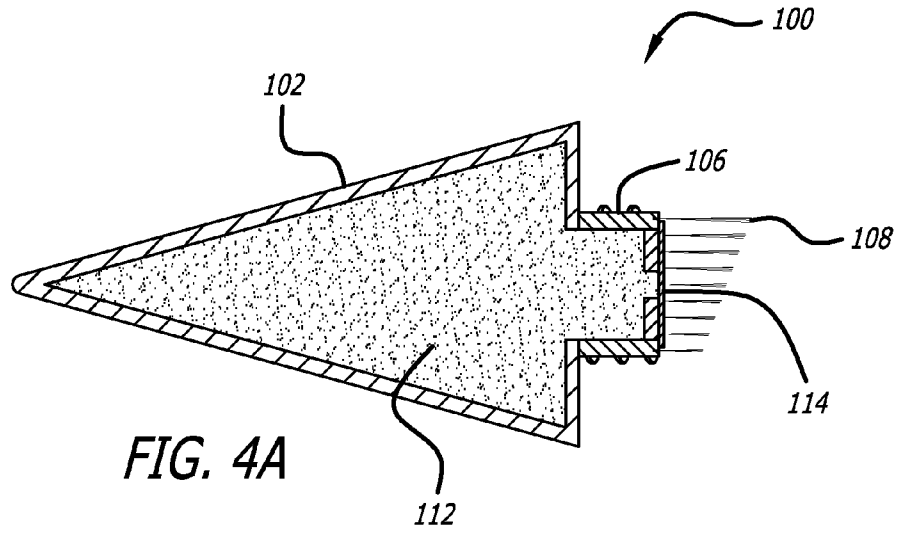
1,947,720 A *	2/1934	Laub	401/7
2,673,362 A	3/1954	Robinson	
3,075,639 A	1/1963	Lingley	
4,530,129 A	7/1985	Labick et al.	
4,880,111 A	11/1989	Bagwell et al.	
5,001,803 A	3/1991	Discko, Jr.	
5,028,158 A	7/1991	Fey	
5,046,212 A	9/1991	O'Conke	

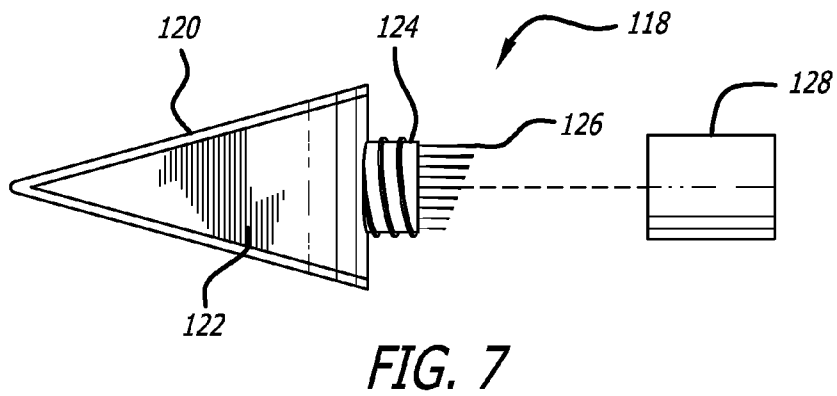
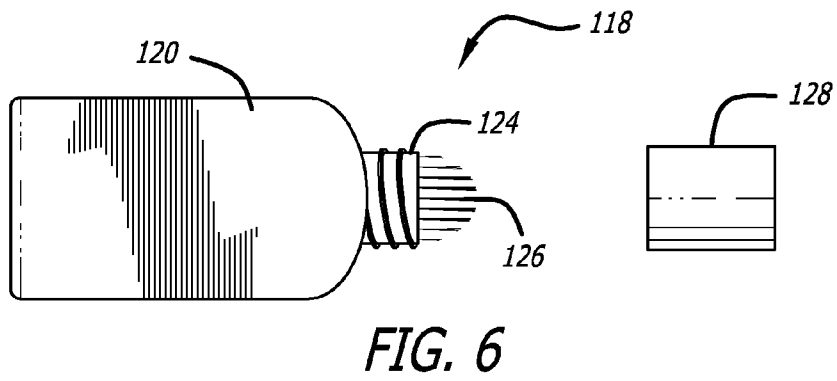
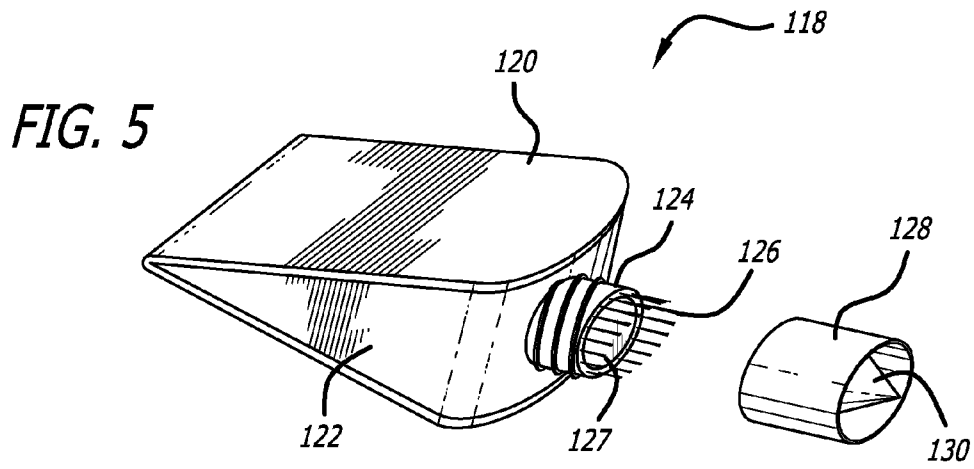
(57) **ABSTRACT**

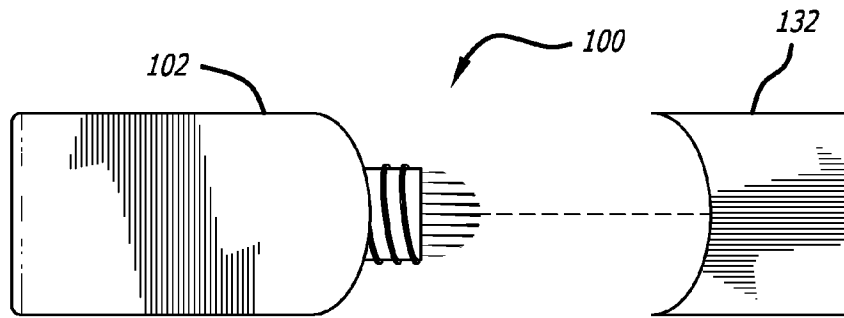
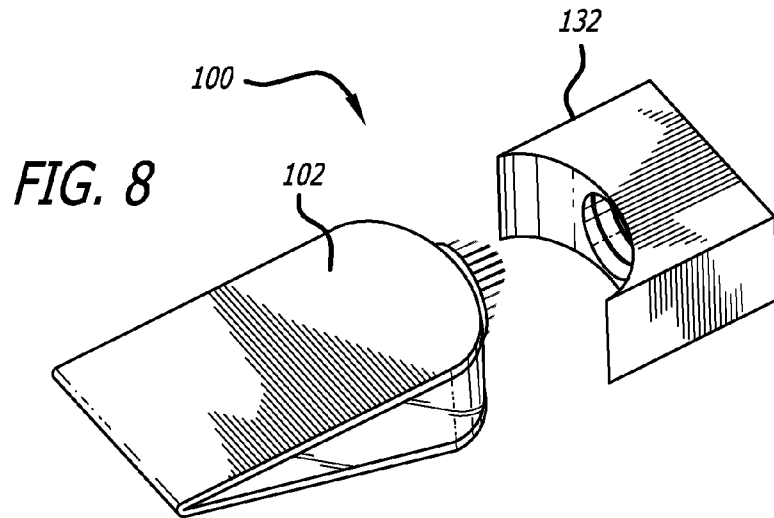
A dental apparatus for cleansing and stain preventing on-the-go is provided in multiple embodiments. One embodiment allows a user to dispose the apparatus after use. Another embodiment allows a user to seal and refill the dental apparatus for repeated use. Further, packaging of various types allows a user to house the dental apparatus in multiple ways.

**11 Claims, 19 Drawing Sheets**

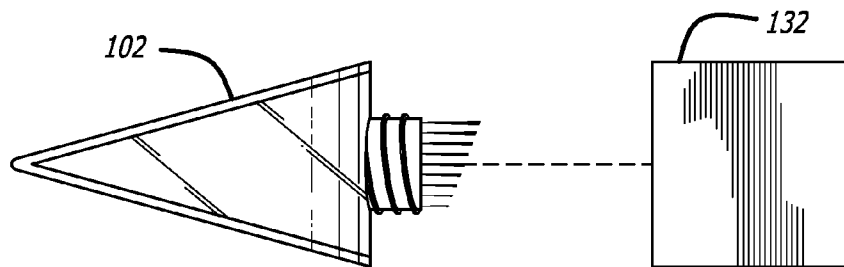








**FIG. 9**



**FIG. 10**

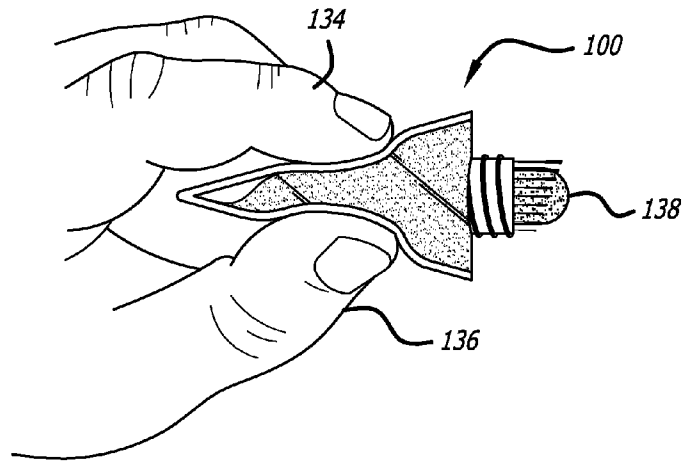


FIG. 11

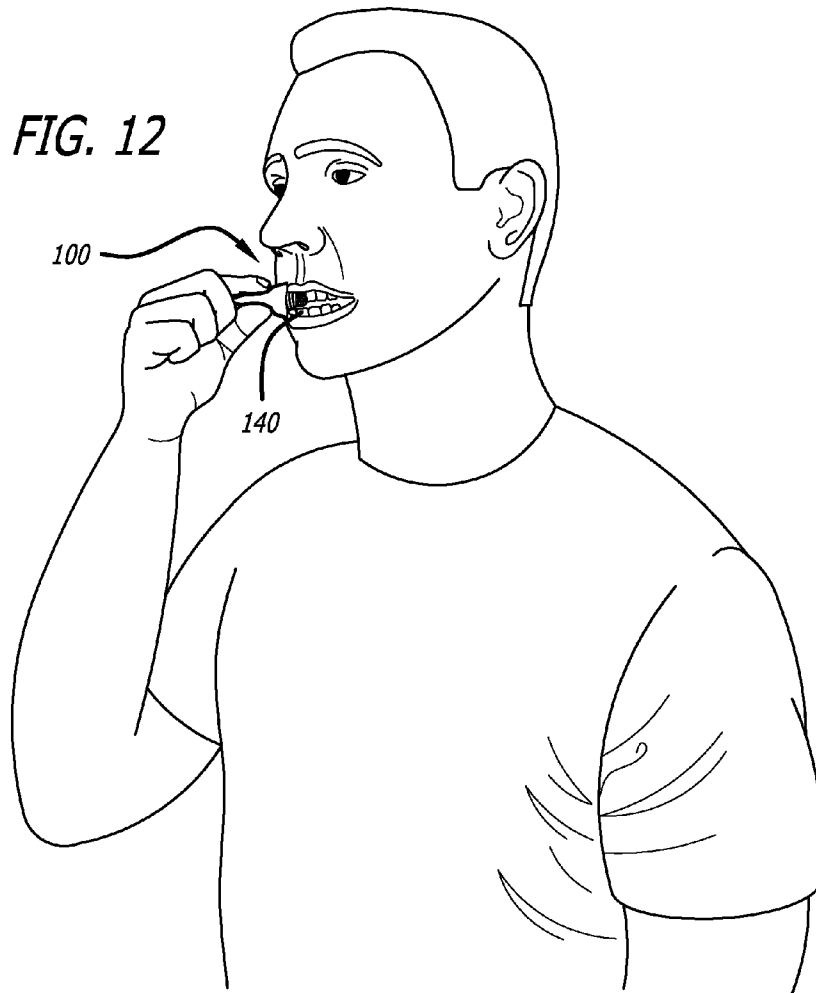
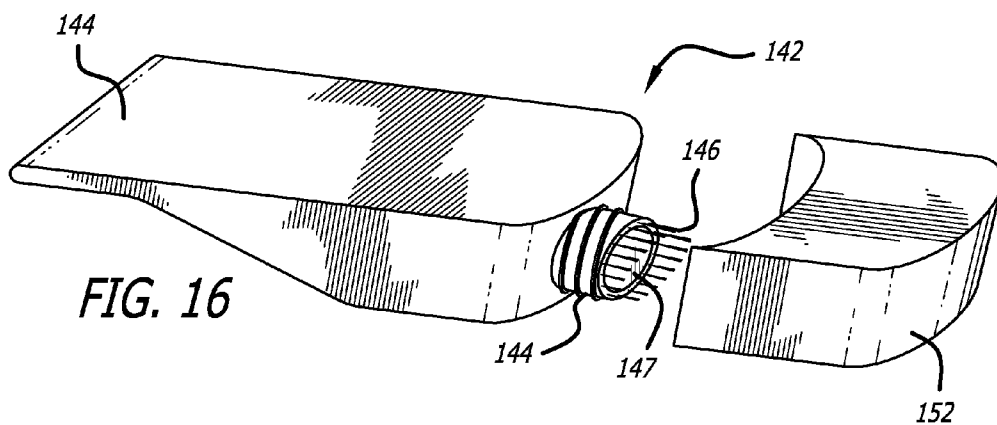
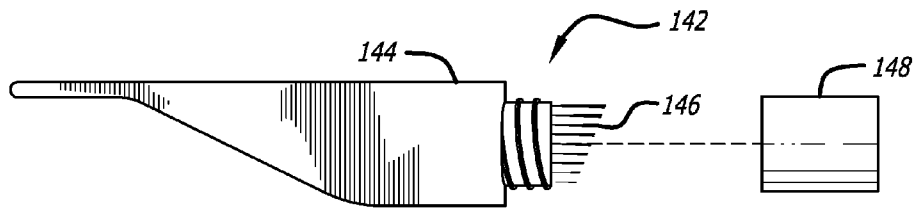
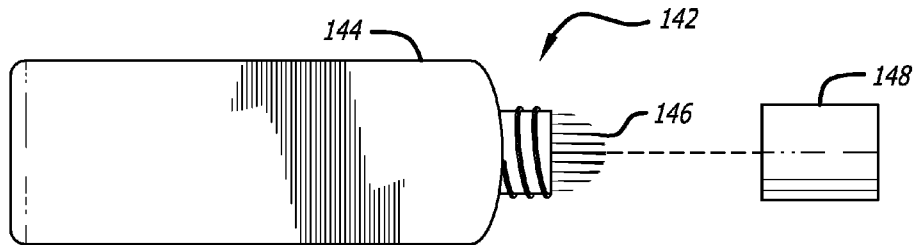
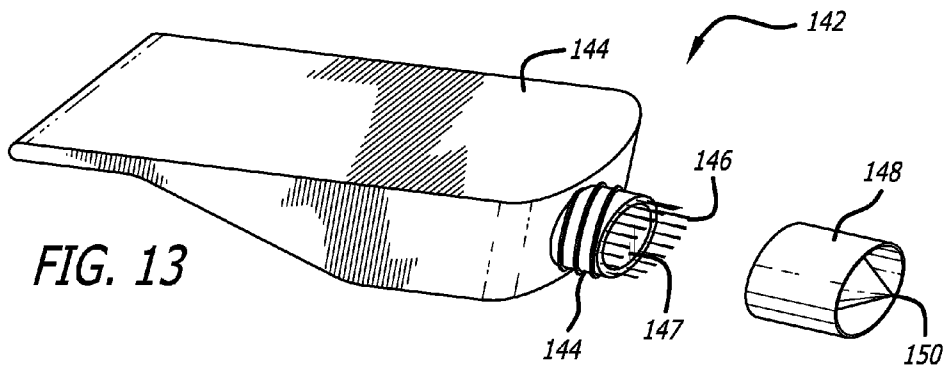
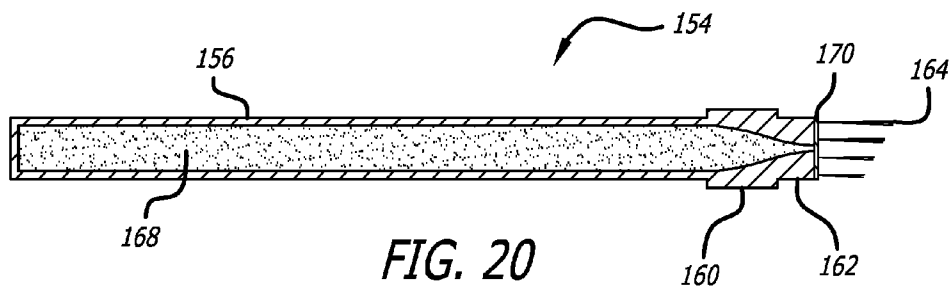
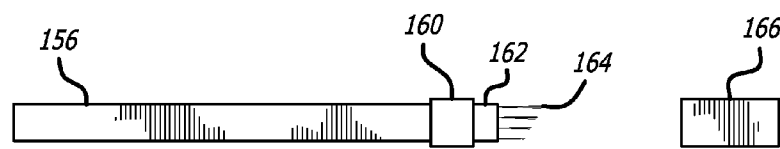
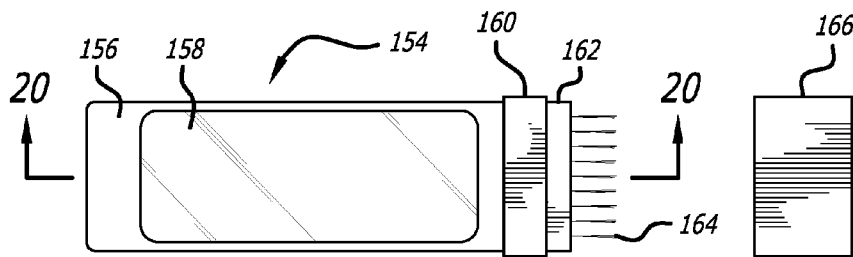
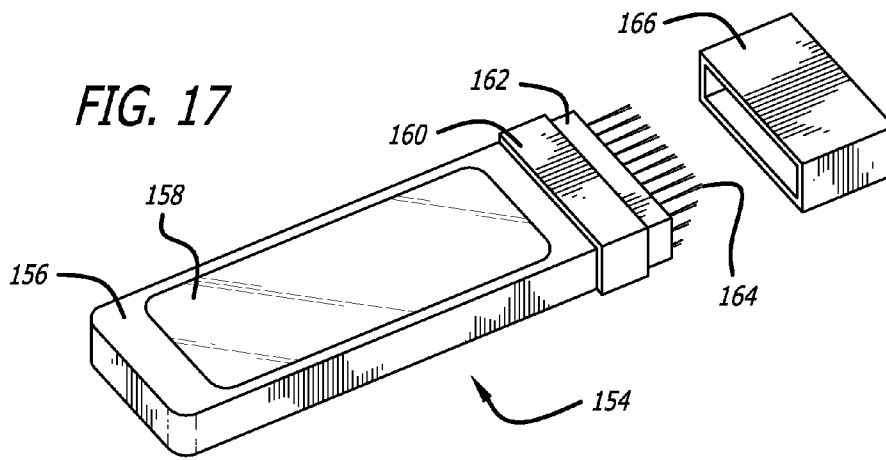
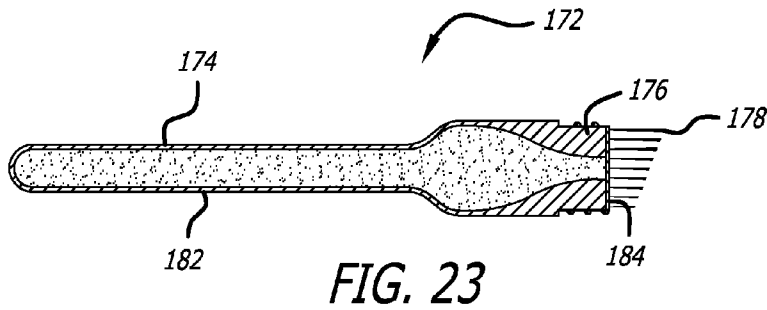
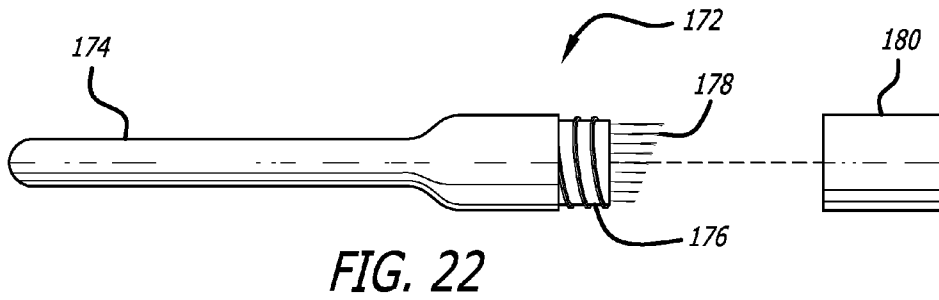
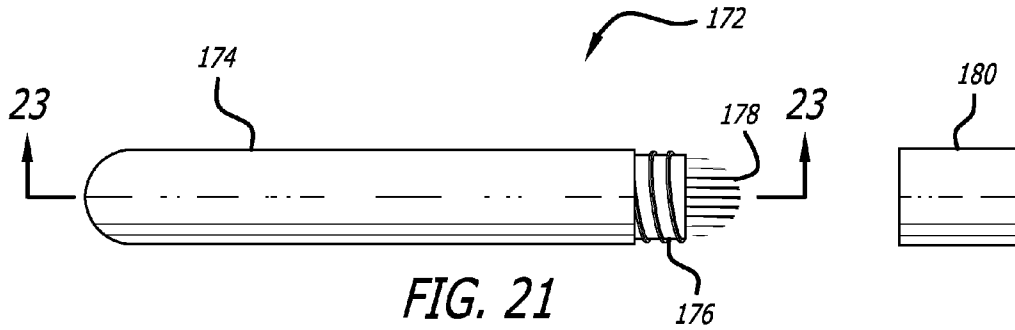


FIG. 12







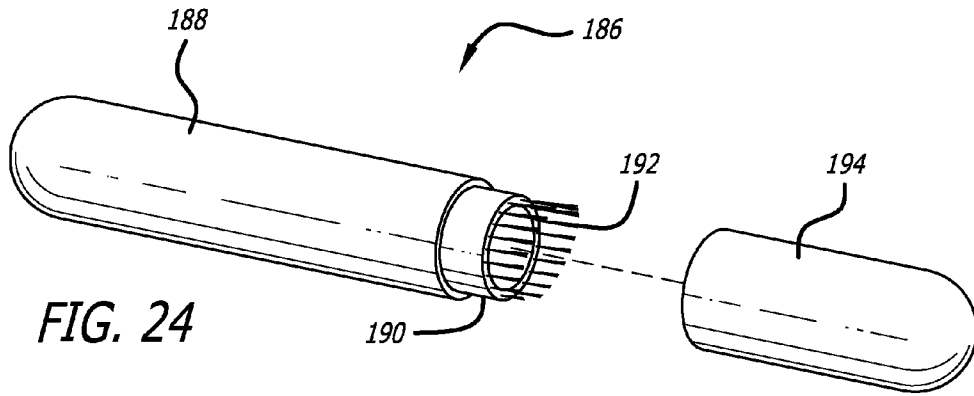


FIG. 24

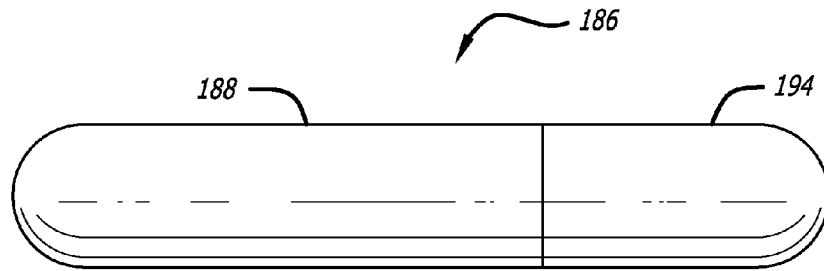


FIG. 25

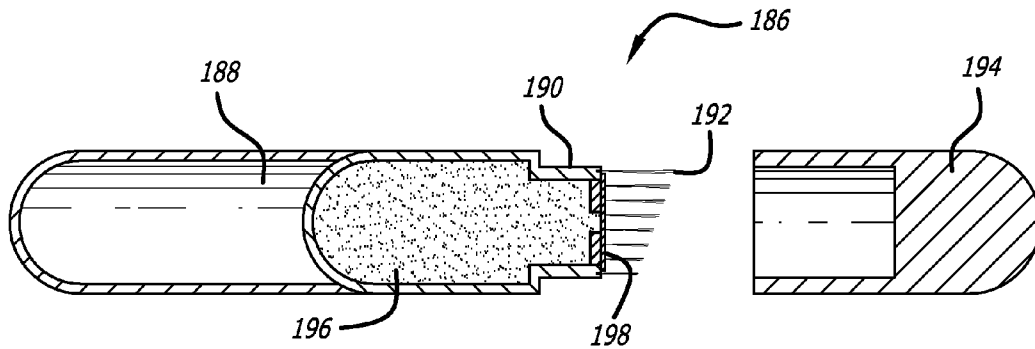


FIG. 26

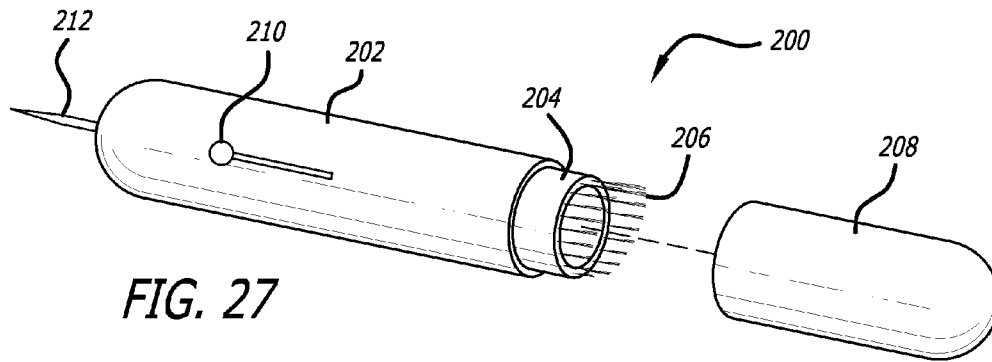


FIG. 27

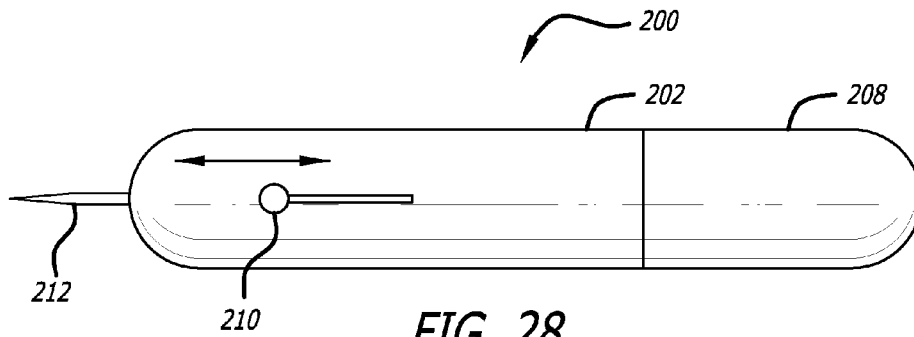


FIG. 28

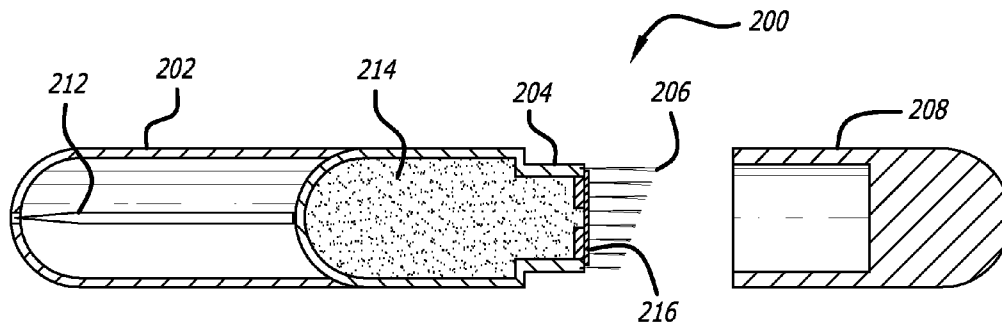
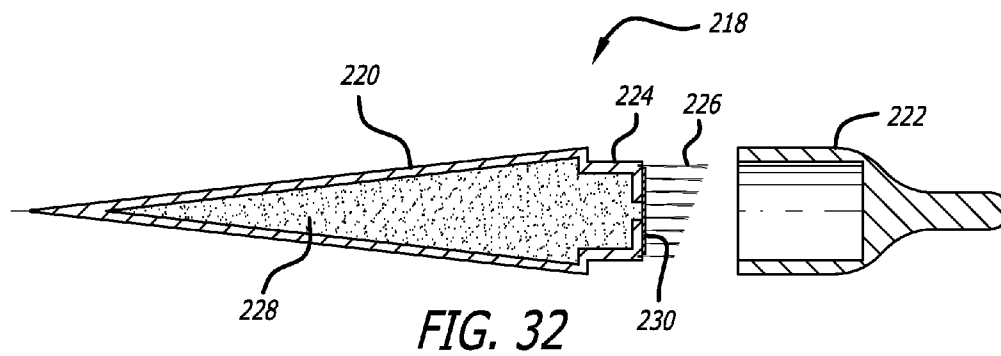
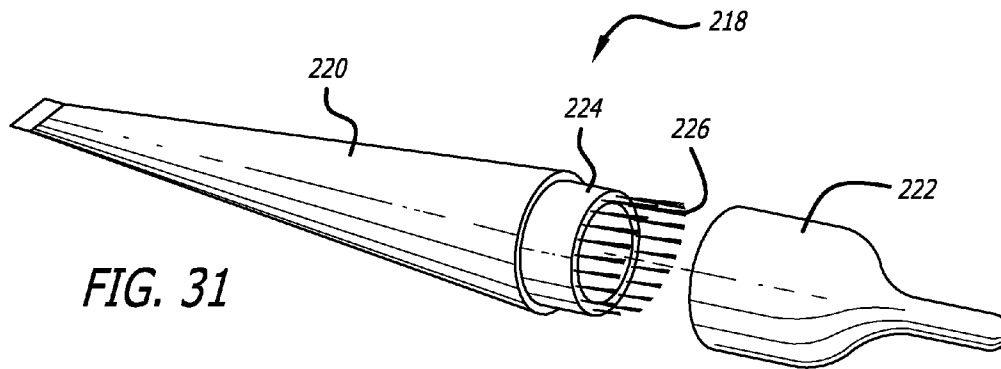
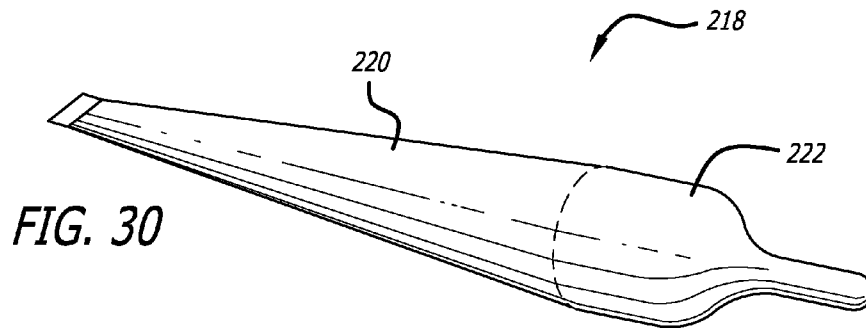
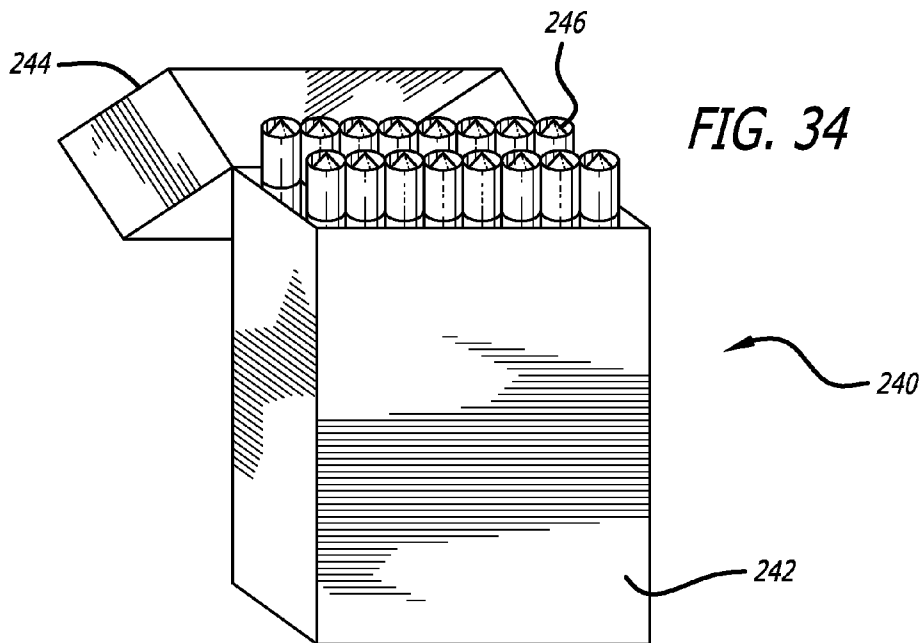
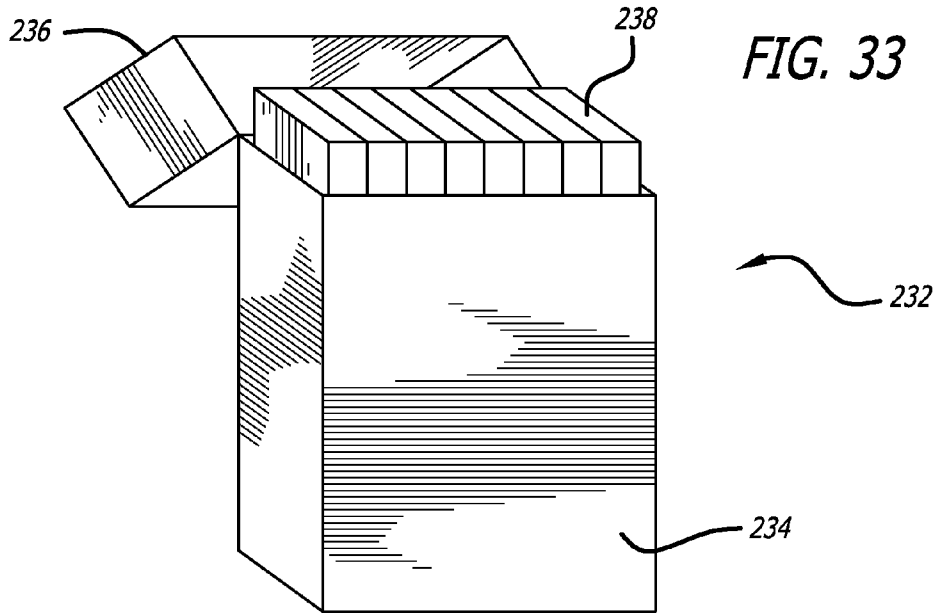
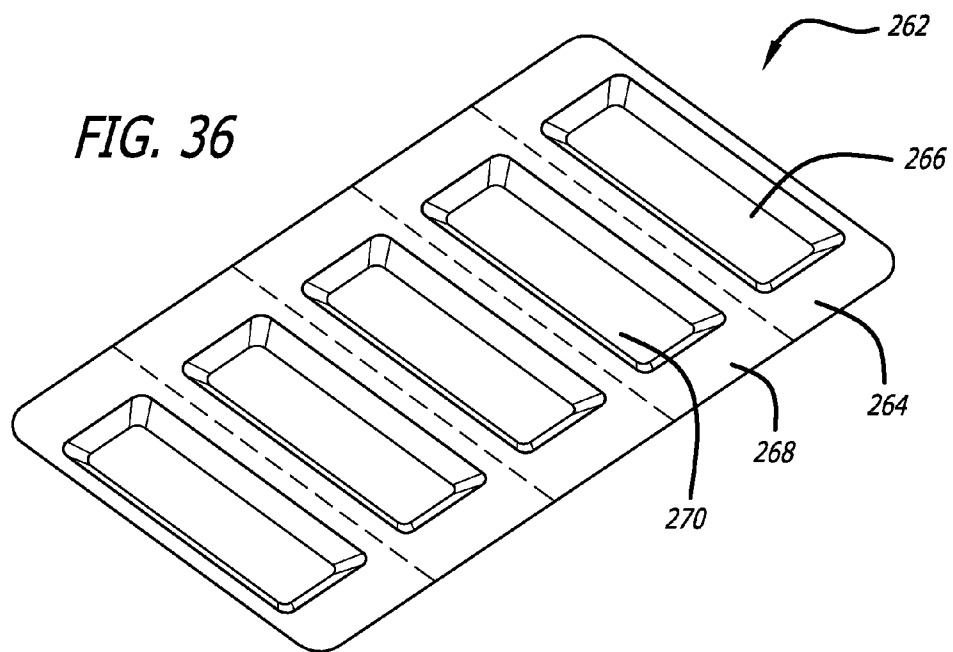
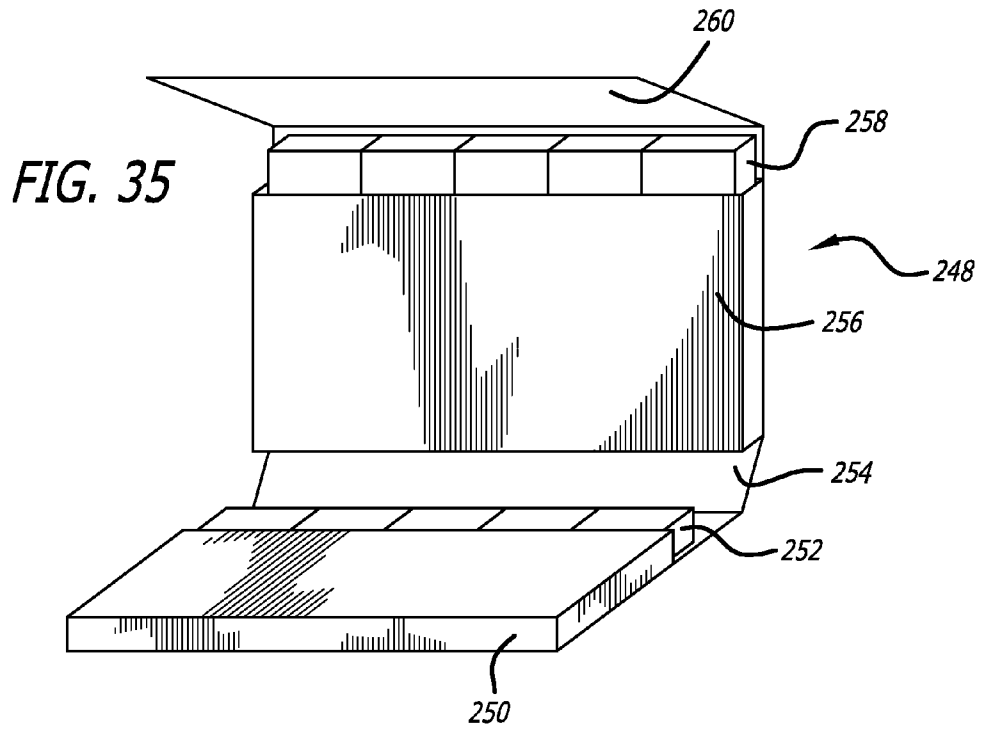


FIG. 29









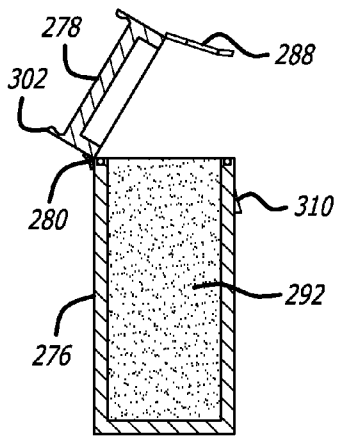
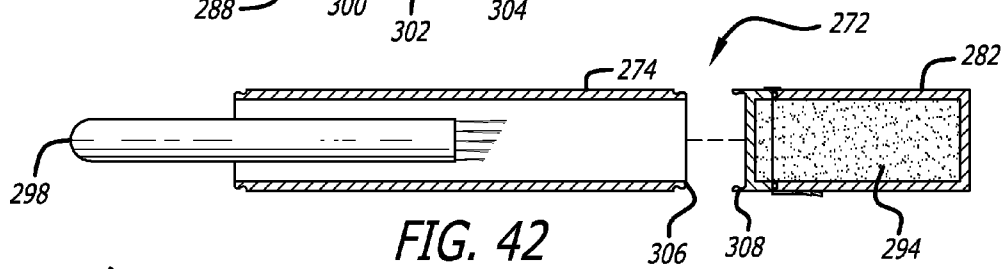
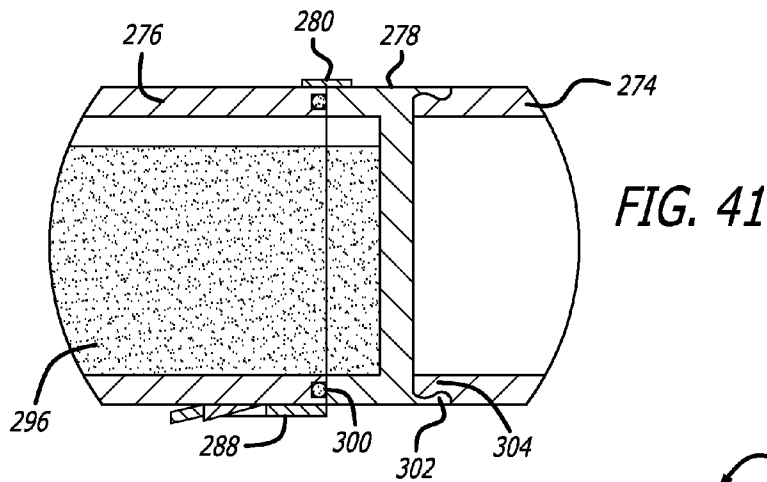


FIG. 43

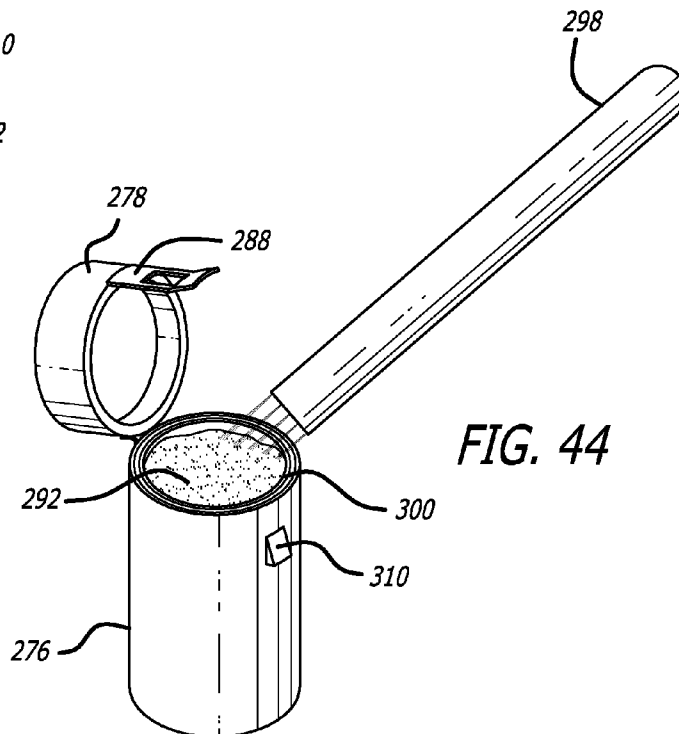


FIG. 44

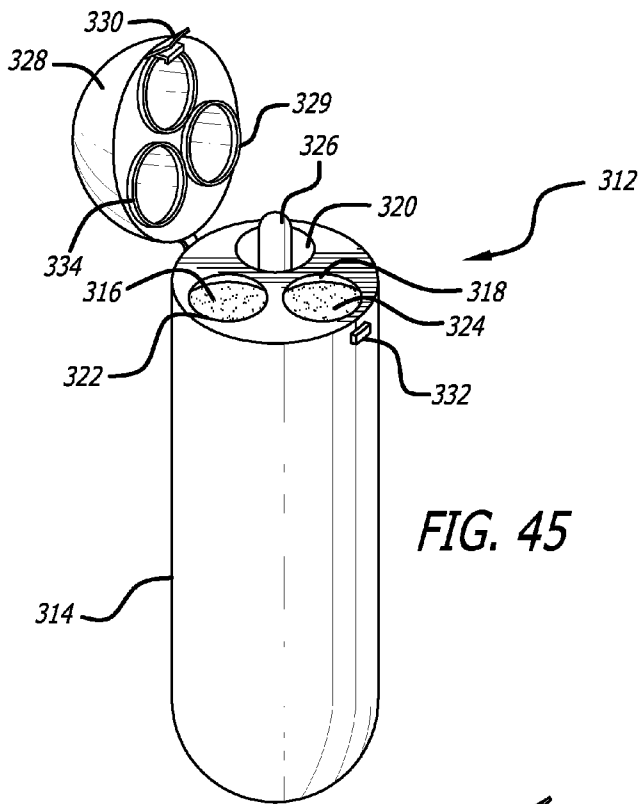


FIG. 45

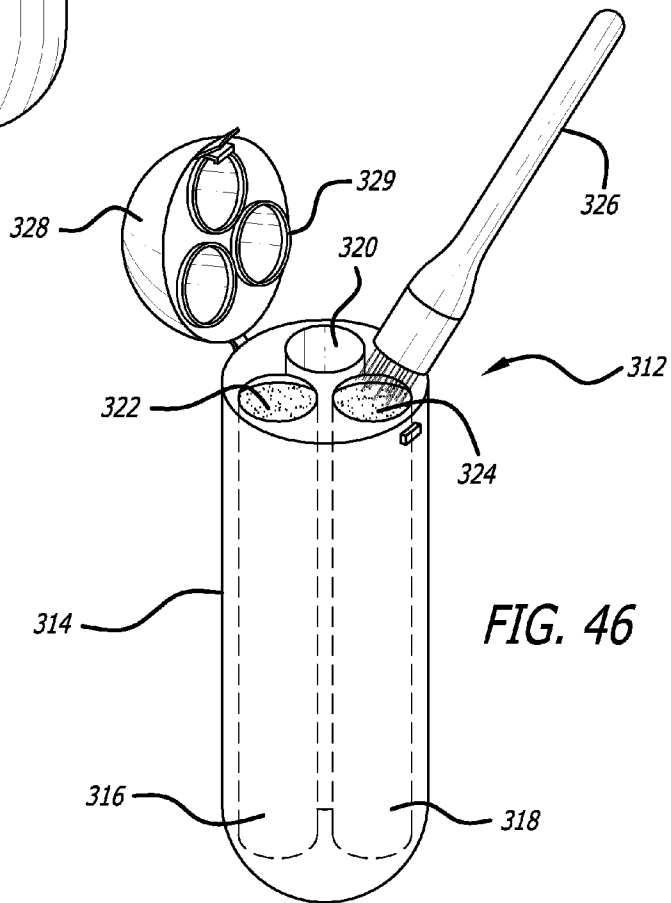


FIG. 46

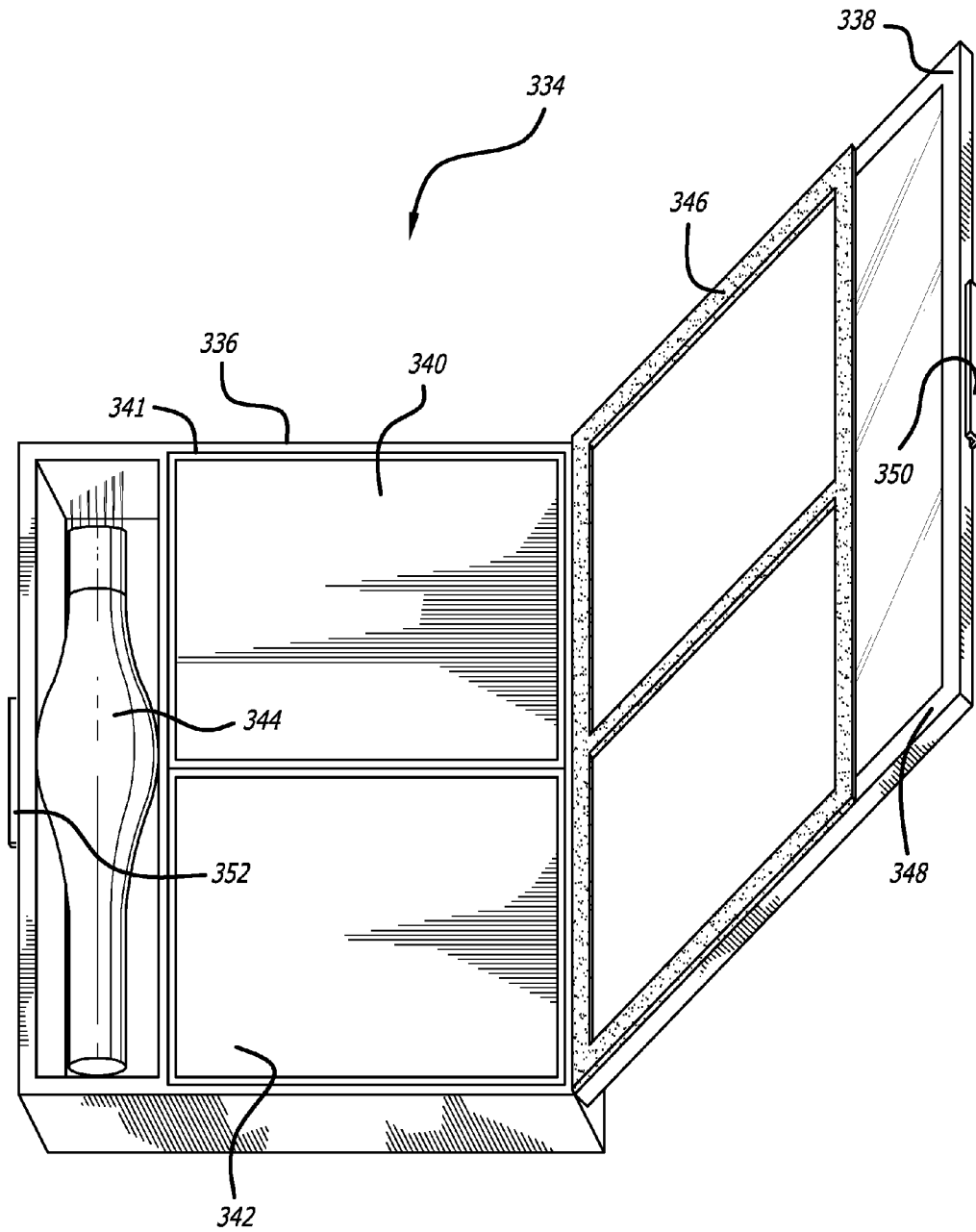
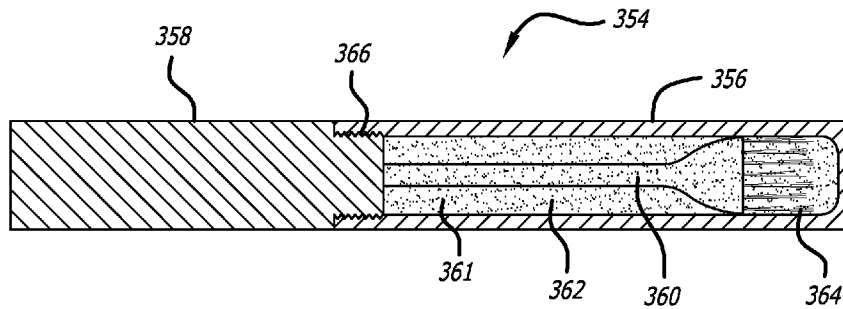
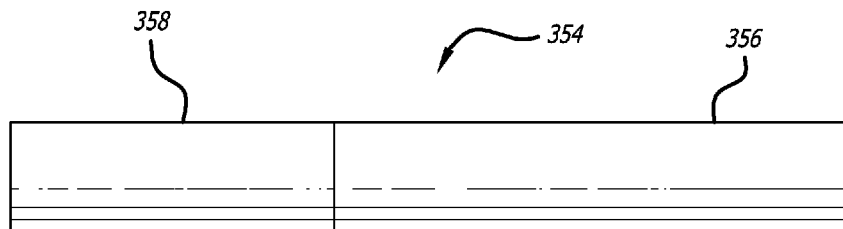
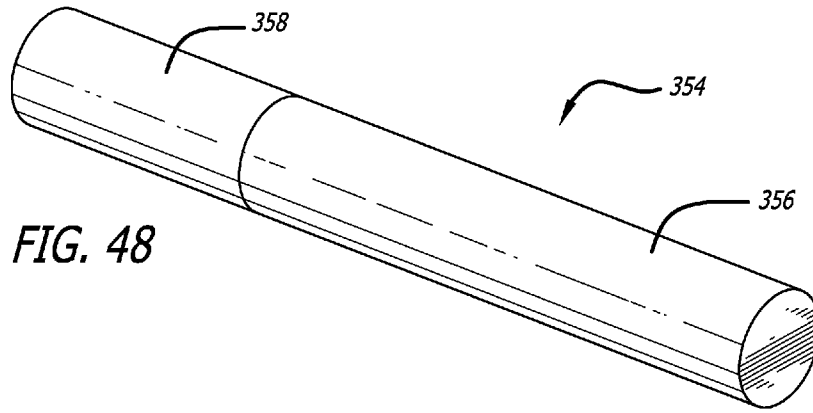


FIG. 47



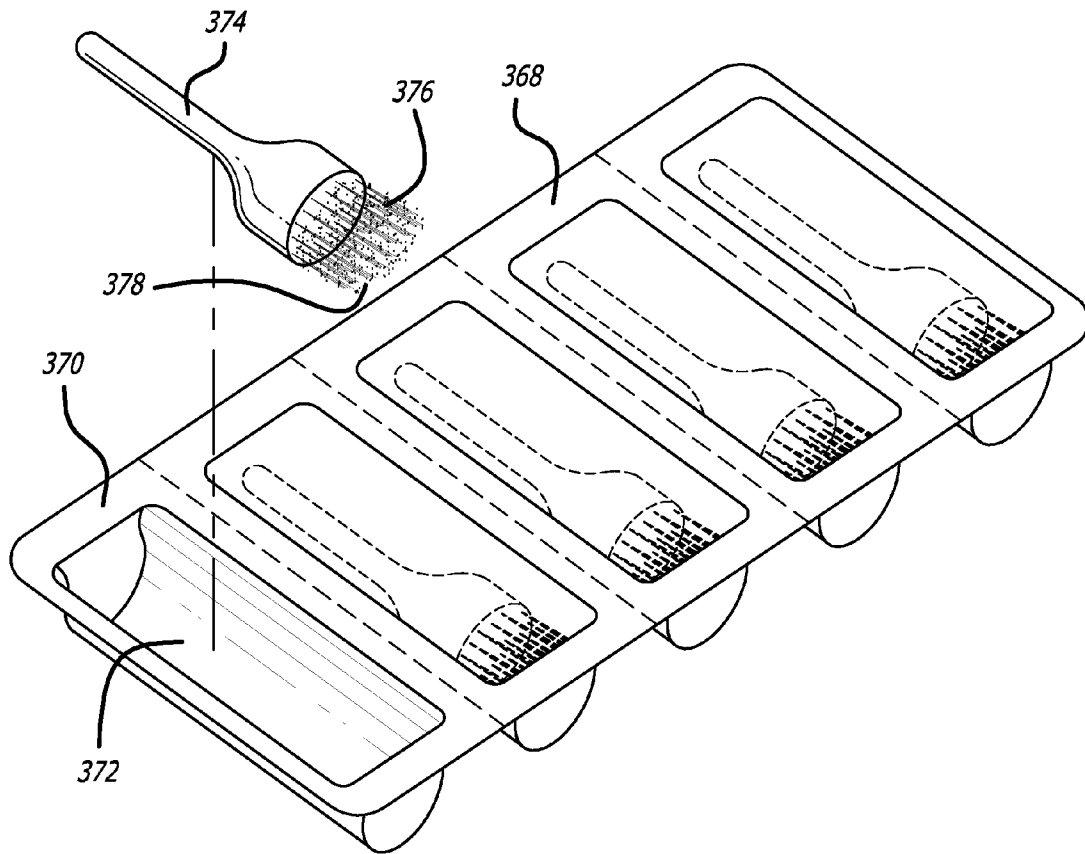


FIG. 51

## DENTAL CLEANSER AND STAIN PREVENTION APPARATUS

### BACKGROUND OF THE INVENTION

#### 1. Field of the Invention

The present invention relates to dental cleansing and stain prevention. Specifically, the present invention is a dental cleanser and stain prevention apparatus. The apparatus includes a convenient ready-to-use form of dentifrice or other similar cleansing compound. The apparatus also serves to prevent dental stains through easy transport and access to cleanser while traveling.

#### 2. Description of the Related Art

There exist various other means by which individuals may clean their teeth. In the prior art, there are other apparatus designed for the purpose of cleansing or whitening individual's teeth. The oldest type of dental cleansing apparatus are brushes. Over time, brushes came to be used primarily in conjunction with dentifrice.

The vast majority of dental cleansing apparatus are designed for consistent home use. For example, brushes are often large enough to fit conveniently within a fully clenched hand and have bristles exposed to the open air. Similarly, conscientious purchasers of dentifrice utilize containers that are several inches in length and more than one or two inches in diameter. These large brushes and dentifrice containers serve to allow a user numerous uses before the brush is degraded to a substantial degree and before an individual need purchase additional dentifrice.

Various other means have also been created, including dental whitening fluids and application means. Individuals have long used toothpicks to remove stubborn food in an effort to quickly clean the teeth and remove stubborn unsightly remaining food parties after a meal. Various types of "mouthwash" have also been created to clean the mouth or freshen breath.

Portable dental freshening and cleansing means are desired by the public and are becoming more common. Small articles capable of cleaning or freshening the individual's breath are increasingly popular. For example, "portable" mouthwash concentrated strips have become popular among those who are concerned about dental freshness. Similarly, chewing breath-freshening gum has been popular for several years.

Gum products have also tried to capitalize on the desire to actually clean teeth on the go. Most modern chewing gum manufacturers market at least one significant line of chewing gum as "whitening" or "dental cleansing" gums. Recent television commercials include claims that chewing gum after meals reduces cavities. Other products make similar claims. While these claims may be true, cleansing the teeth with products designed specifically to clean the teeth, rather than products primarily designed to freshen breath or provide sugar as a candy are substantially more effective.

Modern society, especially working professionals and other individuals who care about their appearance and dental health, is an increasingly a mobile society. Unfortunately, the typical full-size brush and dentifrice containers are not convenient for a user to take with them when they are on-the-go. Similarly, the dental freshening products and chewing gums most often provide little or no actual cleansing of the visible front portion teeth. Instead, they freshen breath and remove excess particles from only the back, less visible portion of the teeth where the gum or product is actually chewed.

Individuals desire the ability to take dental cleaning products with them for use a single time or a few times in a

convenient, small package. Individuals also desire that the products actually clean the teeth and prevent dental stains from occurring.

Some prior art inventions attempt to provide suitable portable dental cleansers. However, these inventions fail in many respects. Most prior art inventions are bulky, complicated to use or are not suited to single, disposable use that are convenient and do not require the need to visit a restroom. Some of the relevant prior art contains glass portions, unsuitable for transport in a purse or glove compartment. Other prior art provides similar functionality, but does not provide for the maintenance of the dentifrice separate from the applicator until such time as the cleanser apparatus is to be used.

For these reasons, there exists in the prior art a need for a compact, ready-to-use dental cleanser and stain prevention apparatus that possibly may not contain harsh chemical whitening ingredients. There is also a need for such apparatus to maintain the dental cleanser conveniently on, and accessible or dispensable from the apparatus separately from the air and debris prior to use and to maintain the dental cleanser free of contact with outside air which may dry or evaporate or possibly contaminate the cleanser.

There is also a need for a compact, ready-to-use dental cleanser and stain prevention apparatus that may be used several times. In the course of multiple uses, there may be a need to provide a means by which the brush may be cleaned on-the-go. There is further a need for the apparatus to maintain the dental cleanser and the brush separate from each other until use. In an alternative embodiment the dental cleanser, a brush cleanser and the brush are separate from each other until use. These and other needs are addressed by the present invention.

### SUMMARY OF THE INVENTION

The invention provides a dental cleanser and stain prevention apparatus for use in maintaining the cleanliness and whiteness of teeth while an individual is on-the-go. The invention provides for a single-use disposable dental cleanser. The invention also provides a dental cleansing apparatus suitable for use on-the-go cleaning in addition to a means by which the brush used for the cleaning may itself be cleaned after use.

The present invention includes multiple embodiments. Several embodiments involve single-use brush and dental cleansing material combinations. In these embodiments, a tapered brush is provided along with a small amount of dentifrice or other suitable dental cleaning material. The tapered brush provides for a more complete cleaning process.

The brush affixed to the end of a chamber includes at least enough dental cleanser for a single use. The chamber may be emptied by squeezing the chamber. The chamber is arranged in one of a series of ways so as to be squeezed by a user. In the preferred embodiment, the dental cleanser is disposed behind a seal which is ruptured, allowing the dental cleanser to exit the chamber through or within the bristles of the brush for quick and easy use. These devices may be housed in a single plastic wrapper.

In another embodiment of the invention, the portable dental cleanser and stain prevention apparatus includes a brush, a dentifrice (or other suitable dental cleaner) and a brush cleanser. There are several ways in which these elements may be combined in a single apparatus.

The brush is maintained in one chamber, the dentifrice is maintained in another and the brush cleanser is maintained in yet another. A user may open the apparatus and gain access to each in turn. First a user accesses the brush, then, with the

brush, accesses the dentifrice and applies it to the brush. A user may then clean the user's teeth while on-the-go.

Once the teeth have been suitably cleaned, the user may access the brush cleanser and applies the cleanser to the brush head. The brush cleanser may act alone or in combination with a small amount of water and in some embodiments a napkin to suitably clean the brush. The user may then seal both the dentifrice and the brush cleanser compartments. The brush is now clean and prepared for on-the-go use at a later time.

The brush is then returned to its storage compartment. The brush may then be removed at a later time for use, along with the dentifrice. It may be cleaned repeatedly over the course of many uses until the dentifrice or brush cleanser is exhausted. The user may then replenish the dentifrice or brush cleanser. Alternatively, the entire unit may be disposed of and a new one may be used.

The novel features which are characteristic of the invention, both as to structure and method of the operation thereof, together with further objects and advantages thereof, will be understood from the following description, considered in connection with the accompanying drawings, in which the preferred embodiment of the invention is illustrated by way of example. It is to be expressly understood, however, that the drawings are for the purpose of illustration and description only, and they are not intended as a definition of the limits of the invention.

#### BRIEF DESCRIPTION OF THE DRAWINGS

FIG. 1 shows a perspective view of a first embodiment of the dental stain prevention apparatus having a transparent skirt.

FIG. 2 shows a plan view of a first embodiment of the dental stain prevention apparatus.

FIG. 3 shows an elevation view of a first embodiment of the dental stain prevention apparatus.

FIGS. 4A and 4B show a cross-section view of a first embodiment of the dental stain prevention apparatus.

FIG. 5 shows a perspective view of a second embodiment of the dental stain prevention apparatus having an opaque skirt.

FIG. 6 shows a plan view of a second embodiment of the dental stain prevention apparatus.

FIG. 7 shows an elevation view of a second embodiment of the dental stain prevention apparatus.

FIG. 8 shows a perspective view of the first embodiment including an alternative cap.

FIG. 9 shows a plan view of one embodiment including the alternative cap of FIG. 9.

FIG. 10 shows an elevation view of the first embodiment including the alternative cap of FIG. 9.

FIG. 11 shows a partial cross-section view of the first embodiment of the dental stain prevention apparatus in use.

FIG. 12 shows the first embodiment of the dental stain prevention apparatus in use.

FIG. 13 shows a perspective view of an alternative embodiment of the invention.

FIG. 14 shows a plan view of the alternative embodiment of FIG. 13.

FIG. 15 shows an elevation view of the alternative embodiment of FIG. 13.

FIG. 16 shows a perspective view of the alternative embodiment of FIG. 13 with an alternative cap.

FIG. 17 shows a perspective view of yet another alternative embodiment of the present invention.

FIG. 18 shows a plan view of the embodiment of FIG. 17.

FIG. 19 shows a side view of the embodiment of FIG. 17.

FIG. 20 shows a cross-sectional view of the embodiment of FIG. 17.

FIG. 21 shows a top view of yet another embodiment of the present invention.

FIG. 22 shows a side view of the embodiment of FIG. 21.

FIG. 23 shows a cross-sectional view of the embodiment of FIG. 21.

FIG. 24 shows a perspective view of yet another alternative embodiment of the present invention.

FIG. 25 shows a closed side view of the embodiment of FIG. 24.

FIG. 26 shows a cross-sectional view of the embodiment of FIG. 24.

FIG. 27 shows a perspective view of the embodiment of FIG. 24 with an additional element.

FIG. 28 shows a plan view of the embodiment of FIG. 24 with the additional element.

FIG. 29 shows a cross-sectional view of the embodiment of FIG. 24 with the additional element.

FIG. 30 shows a perspective view of another alternative embodiment of the present invention.

FIG. 31 shows a perspective view of the embodiment of FIG. 30 with the cap removed.

FIG. 32 shows a cross-sectional view of the embodiment of FIG. 30.

FIG. 33 shows one embodiment of the packaging of the present invention.

FIG. 34 shows an alternative embodiment of the packaging of the present invention.

FIG. 35 shows yet another embodiment of the packaging of the present invention.

FIG. 36 shows yet another embodiment of the packaging of the present invention.

FIG. 37 shows a perspective view of alternative dental cleaning apparatus.

FIG. 38 shows a plan view of the alternative dental cleaning apparatus of FIG. 37.

FIG. 39 shows a cross-sectional view of the alternative dental cleaning apparatus of FIG. 37.

FIG. 40 shows an alternative cross-sectional view of the alternative dental cleaning apparatus of FIG. 37.

FIG. 41 shows a cross-sectional close-up of the snapping mechanism of the apparatus of FIG. 37.

FIG. 42 shows the removal of the brush and dental cleansing mixture.

FIG. 43 shows the opening of the container for the dental cleaning mixture.

FIG. 44 shows the application of the dental cleaning mixture to the brush.

FIG. 45 shows an alternative dental cleaning apparatus.

FIG. 46 shows the alternative dental cleaning apparatus of FIG. 45 in use.

FIG. 47 shows yet another alternative dental cleaning apparatus.

FIG. 48 shows a perspective view of yet another dental cleaning apparatus.

FIG. 49 shows a plan view of the dental cleaning apparatus of FIG. 48.

FIG. 50 shows a cross-sectional view of the dental cleaning apparatus of FIG. 48.

FIG. 51 shows an alternative dental cleaning apparatus.

#### DETAILED DESCRIPTION OF THE INVENTION

Turning first to FIG. 1, a perspective view of one embodiment of the dental cleansing device 100 of the present inven-

5

tion is shown. The dental cleansing device **100** includes an enclosure **102**. The enclosure **102** may be of a rigid material or of a pliable material. Similarly, each of the many embodiments shown herein may be made up of rigid or pliable materials. In the preferred embodiment the enclosure is made up of a rigid plastic or rigid metal alloy. In alternative embodiments it may be made up of a very malleable plastic or alloy.

The enclosure **102** in this embodiment generally takes the cross-sectional shape of a “V.” A malleable plastic skirt **104** is provided to connect one tip of the “V” with another and to thereby enclose the open area created by the “V” of the enclosure **102**. The skirt **104** is clear in this embodiment. As will be seen in later figures, the skirt **104** may instead be translucent or opaque.

Also provided is a threaded neck **106** and a multiplicity of brush-like bristles **108**. The threaded neck **106** is used to affix a cap **110** when the device is not in use or has yet to be used. The cap **110** may or may not be equipped with a puncturing point **112** for use in puncturing a seal provided in the base of the threaded neck **106**. Furthermore, the cap **110** may or may not be a cap that “snaps on” or “breaks off” for use.

Referring now to FIGS. **2** and **3**, a plan perspective and a side perspective of the present embodiment of the invention is shown. Also present in these figure is the enclosure **102**, the skirt **104**, the threaded neck **106** and the bristles **108**. As can be seen, from the top, the bristles **108** appear to be curved in shape (see FIG. **2**). From the side, the bristles **108** taper from top to bottom (see FIG. **3**). This taper is designed such that the bristles **108** may act more fully and efficiently upon the teeth of a user. Also pictured is the cap **110** for use in protecting the bristles and the contents of the device **100**.

Referring now to FIGS. **4A** and **4B**, two cross-sectional views of the device **100** of the present invention are shown. In FIG. **4A**, the enclosure **102**, threaded neck **106** and bristles **108** are shown. In this cross sectional view, the dentifrice **112** may also be seen. Also visible is a seal **114**, provided for the protection of the dentifrice **112** when the device has not yet been used.

The term “dentifrice” is applied to the contents of these various dental cleaning apparatus and devices herein. It is to be expressly understood that “dentifrice” refers to any type of dental cleaning fluid or material. In some cases, the “dentifrice” may be contents typically known as “tooth paste.” In other cases, “dentifrice” may refer to a dental cleaning fluid or liquid formulated to clean teeth without the use of water or the gritty texture of tooth paste. In other embodiments the “dentifrice” may also be a formulated for specific purposes, such as whitening, sensitive teeth or breath freshening. In other embodiments, it may be a sugar free confectionary type product specifically formulated to freshen breath. An understanding of the term “dentifrice” should be broadening, not narrowing unless specifically indicated.

In FIG. **4A**, the seal **114** remains sealed, because the device **100** has not yet been used. It is to be understood that in other embodiments, the seal may be placed at the base of the neck **106** instead of at the head. In FIG. **4B**, the seal is shown in the open position.

In some embodiments of the present invention, the seal **114** must first be broken by the puncturing point **112**. In other embodiments, the seal **114** may be broken through the application of force to the enclosure **102** as shown in FIG. **4B**. This may be provided by creating an intentional weakness in the seal **114** at a point near the middle of the seal **114**. This will allow the seal **114** to break in a pre-determined location when pressure is applied to the enclosure **102**.

As can be seen in FIG. **4B**, the exiting dentifrice **116** moves through a break in the seal **114**. This dentifrice **116** is imme-

6

diately present within the brush bristles **108** and may then be applied to the teeth of a user. The user may then clean his or her teeth.

It may not be clear from a review of FIGS. **1** through **4B** that the present invention is intended to be disposable. The device **100** is of a small size, such that a portion of dentifrice **112** is provided that may be used for one to five uses, at which time the device **100** may be thrown away.

Referring now to FIGS. **5** through **7**, an alternative embodiment of the present invention having an opaque skirt **122** is shown. The device **118** includes an enclosure **120**. As above, the enclosure **120** may be malleable or may be rigid. The device **118** includes an opaque or translucent skirt **122**. The skirt **104** above was transparent. In this embodiment, the primary difference from the prior embodiment is that the skirt **122** is not transparent.

In some instances, transparency may be useful for allowing a user to judge the extent to which the dentifrice product has been depleted. This may be easily ascertained by viewing the interior of the device **100**. In other embodiments, such as this one, the transparency may not be necessary and a user may determine the amount present in the device **118** through other means. Opacity or translucency provides for a more uniform appearance of the entire device **118**.

Also present in the device **118** shown in FIGS. **5** through **7** are the threaded neck **124**, the tapered bristles **126**, the cap **128** and the puncturing point **130**. As above, the puncturing point **130** may or may not be provided and may or may not be necessary to break a seal **127**.

Referring now to FIGS. **8** through **10**, an alternative cap **132** for the device **100** (or alternatively the device **118**) is shown. This cap **132** provides a wide, rectangular head matching the top of the enclosure **102**. The cap **132** may screw or snap on. It is to be understood that the cap **110** and cap **128** may snap or break on and off as well as utilize threads to stay affixed to the devices **100** and **118**, respectively. Similarly, threads may not be provided in the necks **106** and **124**, respectively.

The alternative cap **132** provides a means by which the devices **100** and **118** may be stored within containers (shown in FIGS. **33-36**). The alternative cap **132** allows the user to more readily grasp the devices **100** and **118** when they are stored within various types of containers. It also provides means by which the devices **100** and **118** may be stored within a purse or other small bag and may be more easily recognized by a user searching for them amongst other items. The cap may also be shaped to aid in packaging or for novel differentiation from other products.

Referring now to FIGS. **11** and **12**, the device **100** is shown in use. As force is applied to the device **100**, for example by means of a forefinger **134** and thumb **136**, the dentifrice **138** exits the device **100** near the bristles of the device **100**. It is to be understood that this process is also for the device **118** and the embodiments of the present invention shown in FIGS. **13** through **32** as well.

Referring to FIG. **12**, the device **100** is then placed near the teeth **140** of the user who may then apply the dentifrice **138** to the teeth **140** and use the bristles to brush and clean the teeth. After one or more uses, the device **100** may then be thrown away.

Another alternative embodiment of the present invention is shown in FIGS. **13** through **16**. In this embodiment of the device **142**, the enclosure **144** is tapered at one end to allow its use to be more accessible and easy for a user. Similar to previous embodiments, the exterior may be made of malleable plastic or alloys. There are a threaded neck **144**, tapered bristles **146**, a cap **148** and a puncturing point **150**.

The neck **144** includes a seal **147** to maintain the dentifrice **138** in a suitable state for use. It is to be understood that the threaded neck **144** may be replaced with a non-threaded neck of a “snap on,” “break off” or similar type. As before, an alternative cap **152** may also be provided.

Referring now to FIGS. **17** through **19**, yet another alternative embodiment of the device **154** of the present invention is shown. The enclosure **156** is made of a hardened plastic in the preferred embodiment, but may be made of any similar rigid material. In alternative embodiments, the enclosure **156** may be made more flexible.

In this device **154**, there is a transparent window **158**. The window **158** is made up of a highly-flexible plastic. This window **158** is the place at which a user may apply pressure in order to force the contents of the device **154** out of the device **154**. The transparent window **158** also allows a user to see the contents of the device **154** for use in determining when to dispose of the device **154**.

This device **160** includes a stop **160** and an edge **162**. The edge **162** is immediately adjacent to the tapered bristles **164**. The cap **166** fits snugly over the edge **162** and abuts the stop **160** to thereby cover and protect the bristles **164**. The cap **166** may also “snap” onto the edge **162** which may include one or more ridges onto which the cap **166** may be designed to fit. This embodiment may also provide for removable bristles which may be removed at the stop and replaced with new bristles to allow for multiple uses.

Referring now to FIG. **20**, a cross-sectional view of the device **154** of FIGS. **17** through **19** is shown. As with previous embodiments, the device **154** enclosure **156** is shown along with the stop **160**, the edge **162** and the bristles **164**. As in previous embodiments, the bristles **164** are tapered for ease of use and better access to teeth.

Within the device is contained an amount of dentifrice **168**. As with prior embodiments, a seal **170** is included to maintain the freshness and hydration of the dentifrice **168**. The seal **170** is at the head of the device **154**, just beyond the edge **162**. The seal **170** may be broken by pressure from the dentifrice **168** as it is squeezed by a user. The seal **170** may also be broken by a sharp point, provided on the cap **166** or otherwise. As with previous embodiments a puncturing point may be provided as a portion of the cap **166** for this purpose.

Referring now to FIGS. **21** through **23**, yet another alternative embodiment of the present invention is shown. The device **172** of this embodiment also has an enclosure **174**, preferably made up of a flexible plastic. There are also a threaded neck **176** and tapered bristles **178** to which a cap **180** may be affixed and cover. As with previous embodiments, the cap **180** may include a puncturing point.

A cross-sectional view of the device **172** includes the dentifrice **182** and the seal **184**. As with previous embodiments, the seal **184** may break with the pressure applied by dentifrice **182** or may require puncturing prior to the dentifrice leaving the enclosure **174**. A puncturing point provided in the cap **180** or otherwise may puncture the seal **184** if necessary.

Turning now to FIGS. **24** through **26**, yet another alternative embodiment of the present invention is shown. In this embodiment, the device **186** includes an enclosure **188**, a ridge **190** and tapered bristles **192**. Also included is a cap **194** which fits snugly over the ridge **190** to thereby contain and protect the bristles **192**. In FIG. **25**, the device **186** is shown with the cap **194** attached to the enclosure **188**.

In FIG. **26**, the device is shown in cross-section. The enclosure **188** is cut-away to show the dentifrice **196** within the enclosure **188**. The ridge **190** and the tapered bristles **192** along with the cap **194** are also shown in cross-section.

Also present is the seal **198**, as described in previous embodiments. The seal may be broken with an external device. The seal may also open upon the application of pressure upon the enclosure **188**. The seal **198** is designed to keep the dentifrice clean, moist and protected while the device is in transit or prior to using.

Referring now to FIGS. **27** through **29** an embodiment similar to that of FIGS. **23** through **26** is shown. This embodiment includes one additional element that is useful in dental cleaning. The device **200** includes an enclosure **202** a ridge **204**, tapered bristles **206** and a cap **208** just as the prior embodiment. However, this embodiment also includes a slider **210** and a built-in toothpick **212**.

The slider **210** allows a user to retract and extend the tooth-pick **212**. In some embodiments, the slider may be provided with a number of pre-determined internal ridges designed to hold the slider **210** in place such that the tooth-pick **212** is extended to a particular length. For example, the tooth-pick **212** may be held in place by the slider **210** at positions such as completely extended and completely retracted. The tooth-pick **212** may be provided to a user in this way so that a user may utilize the toothpick to clean larger debris from the user’s teeth prior to cleaning the teeth using the bristles **206**.

In FIG. **29**, the tooth-pick **212** may be seen in the completely-retracted position within the enclosure **202**. The dentifrice **214** may also be seen along with the seal **216** as shown in other embodiments. The seal **216** may be broken by external devices or by the pressure applied to the enclosure **202** by a user.

Turning now to FIGS. **30** through **32**, yet another alternative embodiment of the present invention is shown. In FIG. **30**, the device **218** of the present invention is shown in a closed position. The cap **222** is affixed to the enclosure **220**. In FIG. **31**, it can be seen that the enclosure **220** includes a ridge **224** and tapered bristles **226** as in previous embodiments. The cap **222** has been removed to allow for this view.

This embodiment is generally made of a thin plastic or alloy. The tapered end of the enclosure **220** allows for easier manufacture by machines. The end is simply “crimped” in order to close off each container during manufacture.

In FIG. **32**, a cross-sectional view of this embodiment is shown. The enclosure **220**, ridge **224** and tapered bristles **226** may be seen along with the cap **222**. As with previous embodiments the dentifrice **228** is protected by a seal **230**. The seal serves to keep the dentifrice **228** moist and protected during transit and before use.

Turning now to FIGS. **33** through **36**, various containers for the safe transport, containment and sale of any of the embodiments disclosed are shown. In FIG. **33**, a cigarette-carton-like container **232** is shown. The container **232** includes a rectangular base **234** and a rectangular top **236**. The top of the container **232** may sit snugly over the devices **238** enclosed within. The container **232** fully encloses the devices **238** within so that they may be protected from elements which may contaminate them.

Turning now to FIG. **34**, a similar container **240** is shown, also include a rectangular open base **242** and a flip top **244**. The base **242** is designed in such a way that it may accept a multiplicity of dental cleaning devices. FIG. **33** demonstrates that various types of devices **246** may be enclosed within this type of container **240**. Multiple rows of devices **246** may be enclosed within the container **240**, dependent upon their size and marketing desires of the manufacturer or retailer.

Referring now to FIG. **35**, another alternative container **248** is shown. This container is split into two portions a base portion **250**, containing a plurality of devices **252** and an

upper portion **256**, connected by a cardboard or plastic backing **254**, also containing a plurality of devices **258**. The backing **254** allows the device **248** to be folded in half wherein the upper portion **256**, made up of three side walls and a front, and the base portion **250**, also made up of three side walls and a front, may abut one another and an upper flap **260** may then cover both portions to securely hold the device **248** in a closed position.

Yet another alternative embodiment for a container **262** is shown in FIG. **36**. In this embodiment, the container **262** defines a break-away blister pack which is made up of a series of plastic (in the preferred embodiment) portions perforated such that they may be split into individual containers. Each perforated portion **264** contains an indentation **266** suitable for the placement of one dental cleaning device. Other perforated portions, such as second perforated portion **268**, also include indentations, such as indentation **270**, for use in storing additional dental cleaning devices.

The container **262** may be enclosed with a cardboard top (not shown) which may also be perforated. Accordingly, a user may "tear off" one or more dental cleaning device, such as one enclosed within the perforated portion **264** for later use. These portions **264** may then be opened and the dental cleaning device removed, used and, if a user so desires, disposed.

Referring now to FIGS. **37** through **44**, a different device **272** for dental cleaning and the method of its use is shown. In the preferred embodiment of this invention, the entire device is made of hardened plastic. This device **272** is made up of a number of compartments. There is a brush compartment **274** connected to a dentifrice compartment **276**. The dentifrice compartment **276** includes a cap **278** attached to the dentifrice compartment **276** by a hinge **280**.

A third compartment **282** is connected to the brush compartment **274** by way of a cap **284** also connected by a hinge **286**. The interaction of hinges **280** and **286** in conjunction with the caps **278** and **284** is seen more clearly in FIG. **43**. Also visible in FIG. **38** are the two snap-tight closures **288** and **290** that are used to secure the dentifrice compartment **276** and cleansing fluid compartment **282** to their respective caps **278** and **284**. It is to be understood that this embodiment may be square or rectangular in cross-section as well as the round cross-section that is depicted.

Referring now to FIGS. **39** and **40**, cross-sectional views of the device **272** can be seen. In these views the brush compartment **274**, including inner chamber **275**, the dentifrice compartment **276** and the cleansing fluid compartment **282** may all be seen. In this embodiment the dentifrice compartment **276** includes a hollow chamber **291** which is filed with dentifrice **292**. The cleansing fluid compartment **282**, including a second hollow chamber **283** is filled with cleansing fluid **294**.

The dentifrice **292** may be applied to the brush **296** for use in cleaning the teeth. The cleansing fluid **294** may then be used in the absence of or in conjunction with an external water source, to wash and rinse the brush **296**. In FIG. **40**, an alternative brush **298** is shown. It is to be understood that a variety of brush types may be used.

Referring now to FIG. **41**, a close-up of a portion of FIG. **39** is shown. In this Figure the brush compartment **274** includes an inner chamber **275** (see FIG. **39**), the dentifrice compartment **276** and the cap **278** may be seen in cross-section. The hinge **280** and snap-tight closure **288** may also be seen. The snap-tight closure **288** acts in such a way that a small protuberance **310** (see FIG. **43**) from the exterior of the dentifrice compartment **276** holds the closure **288** in place once it has been pressed over the protuberance.

In this cross-section, seals **300** which encircle the entire circumference of the dentifrice compartment **276** where it meets the cap **278** are also shown. These seals **300** serve to ensure that the second compartment **276** does not leak out its dentifrice **292**. Similar seals, such as seal **295** (see FIG. **39**), are provided in the cleansing fluid compartment to contain the cleansing fluid **294**. These seals serve to keep the brush, dentifrice and dental cleaning fluid (in some embodiments) separated from the atmosphere.

FIG. **41** also shows the snap-in two-part attachment mechanism for the cap **278** to the brush compartment **274**. A ridge **302** extends from one end of the cap **278**. The ridge **302** is circular when viewed from above. This ridge **302** fits snugly into a corresponding groove **304** in the brush compartment **274**. This allows the brush compartment **274** to be combined with the dentifrice compartment **274** for transport and storage.

The removal of the brush **298** from the brush compartment **274** may be seen in FIG. **42**. The brush compartment **274** is also being removed from the cleansing fluid compartment **282**, containing cleansing fluid **294**. The tooth **308** and corresponding groove **306** allow the two compartments to be transported together while also allowing for separation for use.

Referring now to FIG. **43**, the separated dentifrice compartment **276** is shown. In this Figure, the dentifrice **292** is shown, along with the hinge **280**, now in a bent position for opening. The ridge **302** is shown extending upwards from the cap **278**. Simultaneously, the snap-tight closure **288** is shown, along with the protuberance **310** to which it affixes when the cap **278** is closed.

A perspective view of the separated dentifrice compartment **276** along with the brush **298** is shown in FIG. **44**. In this Figure, the cap **278** attached to the dentifrice compartment **276** can be seen. A more clear depiction of the snap-tight closure **288** and the corresponding protuberance **310** may also be seen. Similarly, the seal **300**, extending around the entire circumference of the dentifrice compartment **276** top can be seen. The brush **298** is shown in the midst of applying dentifrice to its bristles for application and use on a user's teeth. In this embodiment, the separate compartments may also be attachable to one another by way of a threaded neck and corresponding threaded compartment as seen in previous figures.

Referring now to FIGS. **45** and **46**, an alternative embodiment of a dental cleaning device **312** is shown. The base **314** of the device **312** includes three compartments **316**, **318** and **320**. The first compartment **316** is filed with dentifrice **322**. The second compartment **318** is filed with cleansing fluid **324**. The third compartment **320** includes a brush **326**.

The cap **328** includes corresponding compartments with seals, such as seal **334** for ensuring that none liquid may exit the device **312** once it is closed. The cap **328** includes a snap-tight closure, which corresponds to a protuberance **332**. When closed the device **312** is designed including the seals such that it is substantially air-tight. As above, it is to be expressly understood that this embodiment may take on any number of cross-sectional shapes including squares or rectangles.

Referring now to FIG. **46** specifically, the device **312** is shown such that the depth of the chambers **316**, **318** and **320** may be seen within the base **314**. The cap **328** is opened and the brush **326** is removed such that cleansing fluid **324** may be applied to clean the brush **326**, for example, after brushing the teeth. When closed, the cap **329** includes seals, such as seal **329**, which maintain each compartment separate from the atmosphere.

An alternative embodiment is shown in FIG. 47. This device 334 includes a base 336 and a lid 338. The device 334 contains a dentifrice compartment 340 a cleansing fluid compartment 342 and a brush 344, also contained with a compartment. In some embodiments, the dentifrice compartment 340 and the cleansing fluid compartment 342 may be removable. In these cases, removable portions, such as portion 341 may be removed when the dentifrice has been depleted and may be replaced with a new portion 341 including a new dentifrice compartment 340. Both the dentifrice compartment 340 and cleansing fluid compartment 342 are provided with a seal 346 in the lid 338 of the device 334. The seal 346 ensures that dentifrice or cleansing fluid do not escape the device 334 into a user's purse, for example, while in transit.

In this embodiment, the compartments 340 and 342 containing a dentifrice and cleansing fluid respectively, may, as an alternative, be removable and replaceable in order for the option of a variety of dentifrice flavors, and the option of omitting the cleaning fluid. Furthermore, in this alternative embodiment, the brushes are also replaceable. As a result, this embodiment could be less expensive to replace individual components. Also, this embodiment could be manufactured including a higher-quality, stylish exterior portion not intended to be replaced.

The device 334 may also include a mirror 348 for viewing one's teeth while using the brush 344. The device 334 is closed such that the lid 338 and the base 336 abut one another. In this position the seal 346 covers the dentifrice compartment 340 and the cleansing fluid compartment 342 and keeps the brush 344 relatively contained. The clasp 350 on the lid 338 snaps closed over a wide protrusion 352 on the base 336.

Referring now to FIGS. 48 through 50, another alternative embodiment of the present invention is shown. In this embodiment, the device 354 includes a lower portion 356 and an upper portion 358. The device 354 may be seen in a perspective view and a side view in FIGS. 48 and 49.

In FIG. 50, a cross-sectional view of the device 354 is shown. In this view it can be seen that the upper portion 358 is solid, while the lower portion 356 is substantially hollow including a hollow cavity 361. The lower portion 356 houses a brush 360, attached to the upper portion 358, that in the closed position is completely submerged in dentifrice 362 such that the bristles 364 of the brush 360 are completely covered in dentifrice for use in cleaning teeth.

The upper portion 358 is affixed to the lower portion 356 by means of threads 366. In alternative embodiments, threads may not be used and instead a tooth and groove or a "snap-in" connection may be used. In any such embodiments, the device 354 be substantially air-tight to protect the dentifrice 362 and to ensure that the device 354 does not leak when closed.

An additional embodiment is shown in FIG. 51. In the device 368 of this embodiment, a plastic backing 370 is provided with a series of indentations (As shown in FIG. 36), such as indentation 372. Into these indentations, a brush 374 may be placed. In this embodiment the bristles 376 of this brush have been pre-treated with sufficient amounts of dentifrice 378 to allow a user to remove the brush 374 from the device 368 and begin brushing immediately.

A user may "snap off" or "push out" one or more brushes, each contained within an indentation, such as indentation 372, and covered with a cardboard or other backing. The backing is applied such that the brush is maintained in a substantially air-tight state. The pre-treated brush 374 may also be individually wrapped in any number of packages. This

way the dentifrice 378 does not harden or otherwise become unsuitable for use. The user may then open the single indentation 372 and remove the brush 374 for use. Once the user has cleaned his or her teeth, the brush 374 may be disposed.

Accordingly, a dental cleanser and stain prevention apparatus has been described. It is to be understood that the foregoing description has been made with respect to specific embodiments thereof for illustrative purposes only. The overall spirit and scope of the present invention is limited only by the following claims, as defined in the foregoing description.

The invention claimed is:

1. A dental cleaning device comprising:
  - a pliable chamber enclosing an area sufficient for a small portion of dental cleanser; dental cleanser enclosed within said pliable chamber;
  - a tubular neck, affixed to one end of said pliable chamber, through which said dental cleanser may pass;
  - a set of bristles, extending from the exterior end of said tubular neck, for use in applying the dental cleanser;
  - a seal, disposed within said tubular neck, for preventing said dental cleanser from having contact with the exterior atmosphere prior to use of the dental cleaning device, said seal being breakable to enable release of at least a portion of said dental cleanser;
  - and, a cap, removably affixed to said tubular neck, for housing said set of bristles and for preventing said seal from breaking and releasing said dental cleanser when said cap is in place wherein said cap includes a puncturing point thereon for puncturing said seal.
2. The dental cleaning device of claim 1, wherein said dental cleanser is a tooth paste.
3. The dental cleaning device of claim 1, wherein said pliable chamber includes at least one translucent portion through which said dental cleanser is visible.
4. The dental cleaning device of claim 1, wherein said bristles are configured to be tapered for ease of use.
5. The dental cleaning device of claim 1, comprising:
  - a retractable toothpick enclosed within said pliable chamber; and
  - a means for extending and retracting said toothpick.
6. The dental cleaning device of claim 1, wherein the device is housed within disposable packaging including an open base connected to a flip top, suitable for single-device dispensation.
7. The dental cleaning device of claim 1, housed within disposable packaging comprising:
  - a first segment, including a first backing, three surrounding walls, and a first front, wherein said first front covers only a portion of a first device;
  - a second segment, including a second backing, connected to said first backing, three surrounding walls and a second front, wherein said second front abuts with said first front when said disposable packaging is closed; and
  - a cover flap, adapted to abut the back of said first backing when said disposable packaging is closed.
8. The dental cleaning device of claim 1, housed within a break away blister pack.
9. The dental cleaning device of claim 1, housed within a single plastic wrapper.
10. The dental cleaning device of claim 1, wherein said tubular neck is threaded.
11. The dental cleaning device of claim 1, wherein said dental cleanser is a dentifrice.